

## FONTANA MIRAGE COMMERCIAL AUTOMATIC MOTION SENSOR FAUCET IN CHROME SPECS

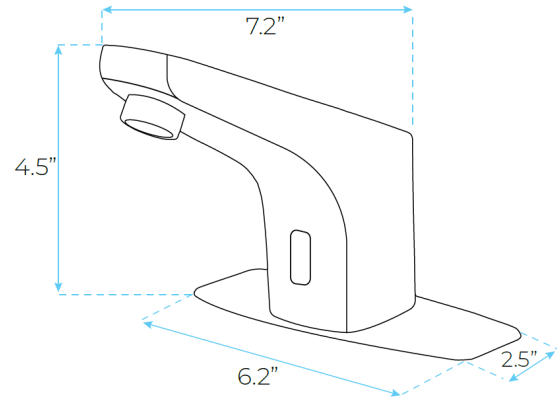

### SPECS:

Power: DC:6V(4AA alkaline battery)

AC:220V-240V; 50/60HZ

Water pressure: 0.05 - 0.8 Mpa

Detection Zone: 30 cm or adjustable

Motor valve lifespan: up to 500000  
flushes

Battery lifespan: 100000 cycles

Static Power Consumption: 0.36mw

Working Power consumption: 0.5mw

Inductive Opening Time: < 1 second

Inductive Closing Time: < 2 second

Dia.of inlet / outlet pipe: G1/2"

Flux:  $\geq 0.07L/S$

Temperature: 0.1-50°C

Dia of installing faucet: 33~35mm

